



On 1 May 2019 The Work Health and Safety Regulations amendments in relation to [Amusement Devices](#) will commence.

In general, our locations may hire an inflatable device e.g. jumping castle which is covered under this regulation, however ownership of such a device incurs specific responsibilities to meet the compliance requirements.

What is an Amusement Device?

amusement device means a device (reference WHS Act Definitions)

(a) used for commercial purposes; and

(b) used or designed to be used for amusement, games, recreation, sightseeing or entertainment,

and on which persons may be carried, raised, lowered or supported by any part of the device

(including, for example, any car, carriage, platform, cage, boat, plank, chair, seat or thing) while the part of the device is in motion.

Inflatable amusement devices

Only inflatable devices that are continuously blown and have a platform height of **3m or more** need to be **registered** with WorkSafe Qld

Measuring Platform Height

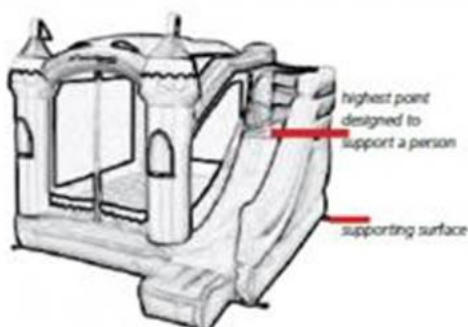

What are the key changes?

- Annual detailed inspection by competent person
 - Inspection of an inflatable device, that is continuously blown, with a platform height **less than 9m** requires a competent person to have the knowledge and skills to inspect the plant gained through training, qualification or experience
 - Inspection where the platform height is **more than 9m** requires the competent person to be registered as a professional engineers
 - Electrical installations to be inspected by an electrician
- Storage -avoid corrosion from moisture
- Mandatory major inspection every 10 years by competent person

What does it mean for our locations?

If you are the owner of the device, then follow the prescribed regulation requirements in relation to:

- Registration

- Inspections
- Storage
- Documentation e.g. log books
- Competent person
- Training

If you hire such a device, then be aware of the required responsibilities of the owner and operator e.g.

- Evidence of inspection and maintenance, log books, +/- WorkSafe Registration
- Their competency and training

A Generic Safe Work Method Statement (SWMS) has also been developed by Qld Synod to assist locations to be aware of potential risks and how they can be managed ([attached](#)).

Please call if you require clarification

Regards

Christine

Christine Przibilla

Work Health and Safety Manager



Uniting Church in Australia
QUEENSLAND SYNOD
Risk and Assurance

Christine.Przibilla@ucaqld.com.au

T: 07 3377 9946 | M: 0439136171 | ucaqld.com.au

F: 07 3377 9716 | GPO Box 674 Brisbane QLD 4001